

Full HD Video FIFO



Features

- 128Mbit density configured as 8M x 16-bit input and output data bus width
- Supports video NTSC, PAL and HDTV up to 1080p resolutions
- Independent 16-bit read/write data bus operations (different I/O data rates acceptable)
- High speed synchronous sequential access in maximum speed 150Mhz
- Input/Output enable control
- Supports double buffer mode (Upper and Lower frame access with 4M x16-bit in each frame) via frame-select pins
- Polarity Selectable
- 2.5V and 3.3V power supply
- Standard LQFP-128 package

Description

The AL460 consists of 128Mbit of memory density, and is configured as 8,192K x 16 bits FIFO (First-In-First-Out), the optimized access scheme offers maximum R/W operating speed up to 150 MHz. The FIFO provides simple and easy-to-use user interfaces facilitating usage in a wide range of applications, such as Multimedia systems, video capture systems, and various video data buffering applications.

Application Scenario

Scenario 1

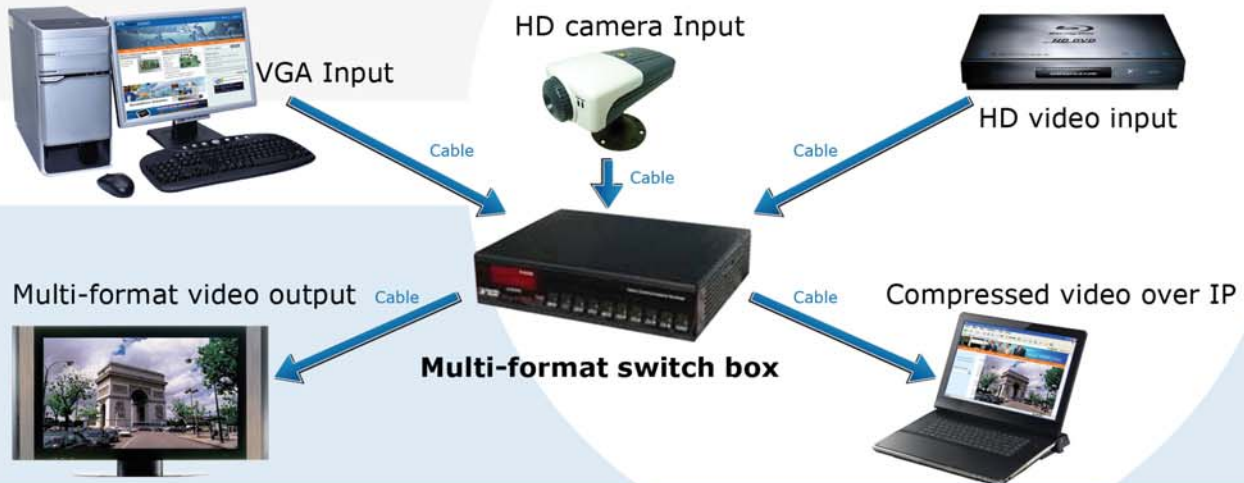

Scenario 2

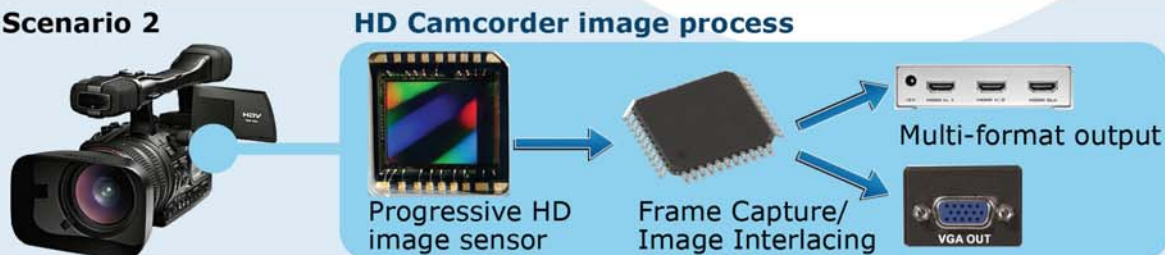

- HD video capturing and editing systems
- Scan rate converters
- Frame synchronizer
- 1080p video stream data buffering

- Switcher or format converter box
- Time base correction (TBC)
- HD digital video camera buffering

Block Diagram

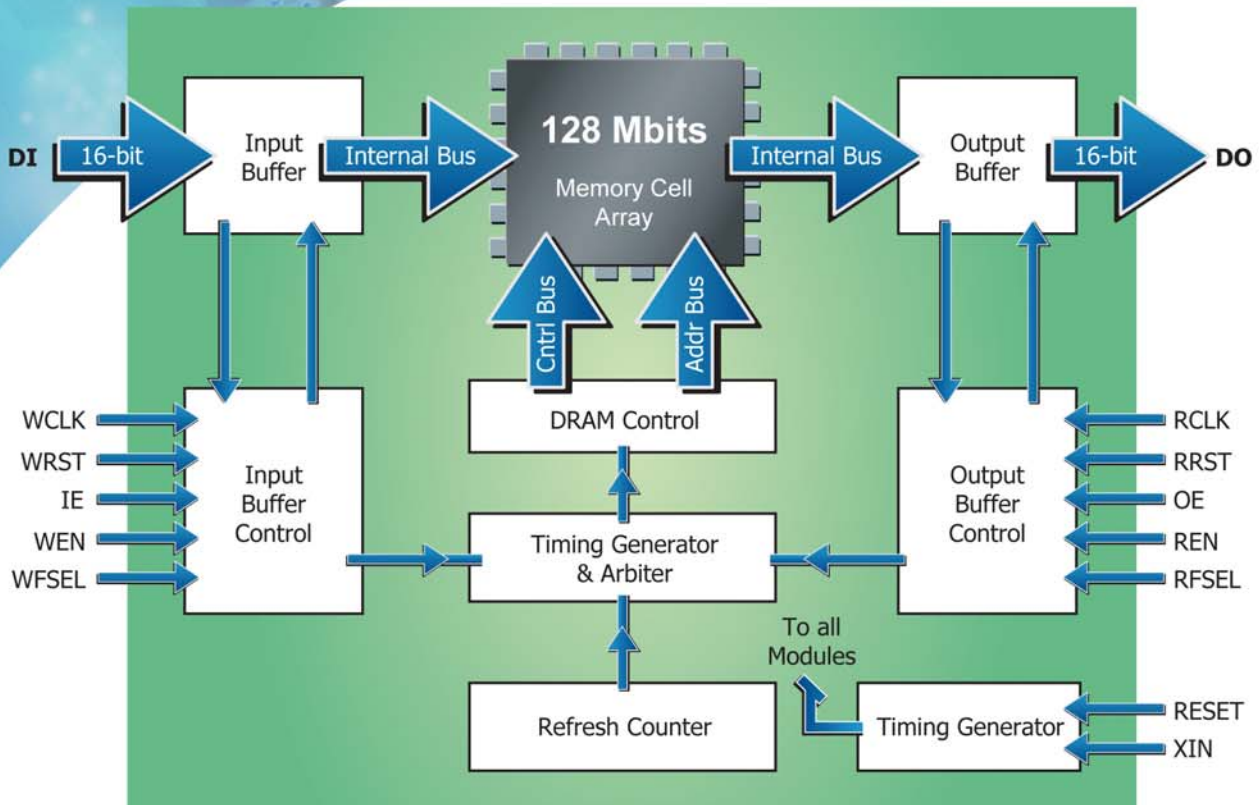

Benefits of Designing with and Using FIFO

The extensive memory size and high data-access-speed allow video frame capturing up to Full HD (1080p) resolution. Complementing the Double Buffer mode, 2 banks serve as upper and lower banks (with 4,096k x 16-bit of each bank), AL460 can be further manipulated into more sophisticated applications. The R/W operations of corresponding banks are acknowledged while high/low signals present at the bank control pins.

All AL460 FIFO specifics, like completely independent input and output controls, built-in address and pointer control circuits, bank switching and other management tasks provide data integrity during access and straightforward bus interface for a sequential data read/write that reduce inter-chip design efforts.

The Double-Buffer mode allocates video data capture without reading a mixed old and new data frames. The polarity control seamlessly matches the controller waveform without additional glue-logic.

The AL460 is also implemented with high performance process technologies with extended controller functions (write mask, read skip .. etc.); allowing easy operation of FIFO read/write for use in broadcasting systems, security systems, cameras, and many other applications.

Designed and manufactured using state-of-the-art technologies, AL460 achieved high performance and low power consumption AC characteristics (2.5/3.3V power supply), for the most sophisticated applications.

The chip is available as an LQFP-128 package; the small footprint keeps real estate of any designs to a minimum.

Ordering Information

| Part number | Package | Power |
|---------------------|----------|-----------|
| AL460A-PBF (150MHz) | LQFP-128 | +2.5/3.3V |



ZWINZ

TECHNICAL CONSULTING GMBH

Tel.: +49(0)8121-5279 Fax: +49(0)8121-41937

Ebersbergerstr. 19, D-85570 Markt Schwaben

info@techconsultzwinz.de www.techconsultzwinz.de